

TRUCK CRANE

TG-500M

TG

JAPANESE SPECIFICATIONS

CARRIER MODEL	SPEC. NO.
NISSAN DIESEL W-KG520TN	TG-500M-4-10103
mitsubishi W-KS506S	TG-500M-4-20103

Control No. JA-01

TG-500M

CRANE SPECIFICATIONS

CRANE CAPACITY

10.65m Boom	50,000kg	at 3.0m	(12 part-line)
18.0m Boom	28,000kg	at 5.0m	(7 part-line)
25.3m Boom	20,000kg	at 6.0m	(5 part-line)
32.7m Boom	14,000kg	at 6.5m	(4 part-line)
40.0m Boom	8,000kg	at 9.0m	(4 part-line)
9.0m Jib	3,500kg	at 75°	(1 part-line)
14.6m Jib	2,500kg	at 78°	(1 part-line)
Single top	4,000kg		(1 part-line)

MAX. LIFTING HEIGHT

Boom	39.5m
Jib	54.0m

MAX. WORKING RADIUS

Boom	34.0m
Jib	38.3m

BOOM LENGTH

10.65m - 40.0m

BOOM EXTENSION

29.35m

BOOM EXTENSION SPEED

29.35m / 122s

JIB LENGTH

9.0m, 14.6m

MAIN WINCH SINGLE LINE SPEED

High range: 102m/min (3rd layer)
Low range: 48m/min (3rd layer)

MAIN WINCH HOOK SPEED

High range: 8.5m/min (12 part-line)
Low range: 4.0m/min (12 part-line)

AUXILIARY WINCH SINGLE LINE SPEED

High range: 95m/min (2nd layer)
Low range: 45m/min (2nd layer)

AUXILIARY WINCH HOOK SPEED

High range: 95m/min (1 part-line)
Low range: 45m/min (1 part-line)

BOOM ELEVATION ANGLE

-3° - 80°

BOOM ELEVATION SPEED

-3° - 80° / 68s

SWING ANGLE

360° continue

SWING SPEED

2.0 rpm

WIRE ROPE

Main Winch

18mm × 215m (Diameter × Length)
7 × 7 + 6 × Fi(29) Class C ordinary · Z twist
Spin-resistant wire rope
Breaking strength 24.3t

Auxiliary Winch

18mm × 130m (Diameter × Length)
7 × 7 + 6 × Fi(29) Class B ordinary · Z twist
Spin-resistant wire rope
Breaking strength 22.3t

BOOM

5-section hydraulically telescoping boom of hexagonal box construction

Two telescoping methods

Telescoping method A
(2nd and 3rd stages synchronized and 4th and 5th stages synchronized)
Telescoping method B
(2nd - 5th stages synchronized)

BOOM EXTENSION

3 double-acting hydraulic cylinder
1 wire rope type telescoping device
With flow regulator valve with pressure compensation

JIB

2-staged type which stores alongside below the base boom section and extendible from under the boom.
(with 2nd stage being a pull-out type)
Hydraulic non-stage offset (5°-45°) type

SINGLE TOP

Single sheave. Mounted to main boom head for single line work.

HOIST

Hydraulic motor driven planetary gear reducer
With free-fall device.
Automatic brake (with foot brake for free-fall device)
2 single winches
With flow regulator valve with pressure compensation

BOOM ELEVATION

2 double-acting hydraulic cylinders
With flow regulator valve with pressure compensation

SWING

Hydraulic motor driven planetary gear reducer
Swing bearing
Hand brake
Swing free/lock changeover type

OUTRIGGERS

Fully hydraulic H-type (floats mounted integrally)
Slides and jacks each provided with independent operation device.

Full extended width 7.4m
Middle extended width 4.6m

FRONT JACK

Hydraulic operated type

MAX. OUTRIGGER LOAD

47.0t

HYDRAULIC PUMPS

4 gear pumps

HYDRAULIC OIL TANK CAPACITY

675 liters

SAFETY DEVICES

Automatic moment limiter (AML)
With working range limiting function

Over-winding cutout

Level gauge

Working area control device

Outrigger extension width detector

Hook safety latch

Cable follower

Winch drum lock

Winch drum rotation indicator

Swing lock

Hydraulic safety valve

Telescopic counterbalance valve

Elevation counterbalance valve

Jack pilot check valve

Front jack grounding detector

Front jack over load alarm

EQUIPMENTS

Crane cab heater

Oil cooler

Boom angle indicator

Radio

Fan

Block

CARRIER SPECIFICATIONS

MANUFACTURER

NISSAN DIESEL MOTOR CO., LTD

CARRIER MODEL

W-KG520TN

ENGINE

Model RF8

Type 4-cycle V8-cylinder, direct-injection, water-cooled diesel engine

Piston displacement 16,991 cc

Max. output 340PS at 2,200rpm

Max. torque 120kg·m at 1,400rpm

CLUTCH

Dry single-plate coil spring type

TRANSMISSION

7-forward and 1-reverse speeds

Synchronized-mesh gear (for 2nd - 7th speeds)

REDUCER

Hypoid gear type

FRONT AXLE

Reverse Elliot-type steel pipe cross section
(with stabilizers on front and rear axles)

REAR AXLE

Full floating, cast torque rods

SUSPENSION

Front Laminated leaf spring type

Rear Equalizer and torque rods

STEERING

Recirculating ball screw type with linkage power assistance

BRAKE SYSTEM

Service Brake

2-circuit air brake, 8-wheels internal expanding brake.

Parking Brake

Mechanically operated, duo-servo shoe type acting on drum at transmission case rear.

Auxiliary Brake

Electro-pneumatic operated exhaust brake.

Emergency

Spring brake

ELECTRIC SYSTEM

24 V DC. 2 batteries of 12V-115F51(96Ah)

FUEL TANK CAPACITY

300 liters

CAB

Two-man type

TIRES

Front 13.00R20-24PR

Rear 11.1-20-16PR

STANDARD EQUIPMENTS

Car heater

Car radio

GENERAL DATA

DIMENSIONS

Overall length 12,850mm

Overall width 2,820mm

Overall height 3,750mm

Wheel base 1,470mm + 3,780mm + 1,400mm = 6,650mm

Tread Front 2,230mm

Rear 2,110mm

WEIGHTS

Gross vehicle weight

Total 38,470kg

Front 18,180kg

Rear 20,290kg

PERFORMANCE

Max. traveling speed 65km/h

Min. traveling speed 1.2km/h

Gradeability (tan θ) 0.57

Min. turning radius 11.0m

CARRIER SPECIFICATIONS

MANUFACTURER

MITSUBISHI MOTOR CORPORATION

CARRIER MODEL

W-KS5065

ENGINE

Model 8DC10

Type 4-cycle V8-cylinder, direct-injection, water-cooled diesel engine

Piston displacement 16,752cc

Max. output 335PS at 2,200rpm

Max. torque 120kg-m at 1,300rpm

CLUTCH

Dry single-plate type

Hydraulic control with clutch booster

TRANSMISSION

10-forward and 2-reverse speeds

Constant-mesh gear (1st speed, 2nd speed, reverse)

Synchronized-mesh gear (for 3rd - 10th speeds)

REDUCER

1-stage speed reduction type

Hypoid gear type

FRONT AXLE

Reverse-elliot type steering knuckles

REAR AXLE

Full-floating type; cast-steel housing

SUSPENSION

Front Laminated semi-elliptical leaf spring type

With torsion bar stabilizer

(only for the front front axle)

Rear Equalizer beam and torque rod type

STEERING

Recirculating ball screw type

With linkage type hydraulic power booster

BRAKE SYSTEM

Service Brake

2-circuit air brakes for all wheels

Leading and trailing shoe type.

Parking Brake

Spring brake, acting on 4 rear wheels

Auxiliary Brake

Exhaust brake

ELECTRIC SYSTEM

24 V DC. 2 batteries of 12V-145F51 (112Ah)

FUEL TANK CAPACITY

300 liters

CAB

Two-man type

TIRES

Front 13.00R20-24PR

Rear 11.00-20-14PR

STANDARD EQUIPMENTS

Car heater

Car radio

GENERAL DATA

DIMENSIONS

Overall length 12,860mm

Overall width 2,820mm

Overall height 3,750mm

Wheel base 1,450mm + 3,850mm + 1,350mm = 6,650mm

Tread Front 2,240mm

Rear 2,050mm

WEIGHTS

Gross vehicle weight

Total 38,480kg

Front 17,895kg

Rear 20,585kg

PERFORMANCE

Max. traveling speed 70km/h

Min. traveling speed 1.9km/h

Gradeability (tan θ) 0.33

Min. turning radius 11.0m

TOTAL RATED LOADS

[TELESCOPING METHOD a]

Unit : ton

Outriggers fully extended (Over rear · Over sides)					
A \ B (m)	10.65 m	18.0 m	25.3 m	32.7 m	40.0 m
3.0	50.00	28.00			
3.5	43.00	28.00			
4.0	38.00	28.00	20.00		
4.5	34.00	28.00	20.00		
5.0	30.20	28.00	20.00		
5.5	27.50	25.60	20.00	14.00	
6.0	25.00	23.50	20.00	14.00	
6.5	22.70	21.80	18.60	14.00	8.00
7.0	20.70	20.00	17.30	13.50	8.00
7.5	18.90	18.50	16.20	13.00	8.00
8.0	17.40	17.00	15.30	12.50	8.00
8.5	16.05	15.70	14.40	11.90	8.00
9.0	14.90	14.70	13.60	11.30	8.00
10.0		12.20	12.05	10.30	7.50
11.0		10.20	10.05	9.40	6.95
12.0		8.60	8.45	8.60	6.45
13.0		7.30	7.20	7.90	6.00
14.0		6.25	6.05	6.75	5.60
16.0		4.50	4.35	5.15	4.85
18.0			3.25	3.95	4.25
20.0			2.30	3.05	3.60
22.0			1.60	2.30	2.85
24.0				1.70	2.25
26.0				1.30	1.80
28.0				0.85	1.35
30.0					1.00
32.0					0.70
34.0					0.40

A = Boom length B = Working radius

[TELESCOPING METHOD a]

Unit : ton

Outriggers fully extended + Front jack (Over front)					
A \ B (m)	10.65 m	18.0 m	25.3 m	32.7 m	40.0 m
3.0	50.00	28.00			
3.5	43.00	28.00			
4.0	38.00	28.00	20.00		
4.5	34.00	28.00	20.00		
5.0	30.20	28.00	20.00		
5.5	27.50	25.60	20.00	14.00	
6.0	25.00	23.50	20.00	14.00	
6.5	22.70	21.80	18.60	14.00	8.00
7.0	20.70	20.00	17.30	13.50	8.00
7.5	18.90	18.50	16.20	13.00	8.00
8.0	17.30	17.00	15.30	12.50	8.00
8.5	15.50	15.30	14.40	11.90	8.00
9.0	13.90	13.75	13.60	11.30	8.00
10.0		11.30	11.20	10.30	7.50
11.0		9.45	9.35	9.40	6.95
12.0		7.95	7.85	8.60	6.45
13.0		6.75	6.65	7.50	6.00
14.0		5.80	5.70	6.50	5.60
16.0		4.30	4.20	5.00	4.85
18.0			3.10	3.85	4.25
20.0			2.25	3.00	3.40
22.0			1.60	2.30	2.75
24.0				1.70	2.15
26.0				1.30	1.70
28.0				0.85	1.30
30.0					1.00
32.0					0.70
34.0					0.40

A = Boom length B = Working radius

[TELESCOPING METHOD a]

Unit : ton

<ul style="list-style-type: none"> · Outriggers middle extended (360°) · Outriggers fully extended (Over front) 					
A B (m)	10.65 m	18.0 m	25.3 m	32.7 m	40.0 m
3.0	40.00	28.00			
3.5	34.00	28.00			
4.0	28.60	28.00	20.00		
4.5	25.40	25.30	20.00		
5.0	19.10	18.90	18.80		
5.5	14.90	14.80	14.70	14.00	
6.0	12.10	12.00	11.90	14.00	
6.5	10.00	9.95	9.80	11.10	8.00
7.0	8.35	8.30	8.20	9.40	8.00
7.5	7.10	7.05	6.95	8.10	8.00
8.0	6.05	6.00	5.90	7.00	7.60
8.5	5.20	5.15	5.05	6.15	6.80
9.0	4.45	4.40	4.30	5.35	6.00
10.0		3.20	3.25	4.15	4.70
11.0		2.35	2.30	3.20	3.70
12.0				2.50	3.00
13.0					2.40

A = Boom length B = Working radius

[TELESCOPING METHOD b]

Unit : ton

Outriggers fully extended (Over rear · Over sides)							
A \ B (m)	10.65 m	18.0 m	21.7 m	25.3 m	29.0 m	32.7 m	40.0 m
3.0	50.00	14.00					
3.5	43.00	14.00	14.00				
4.0	38.00	14.00	14.00	14.00			
4.5	34.00	14.00	14.00	14.00	14.00		
5.0	30.20	14.00	14.00	14.00	13.20		
5.5	27.50	14.00	14.00	14.00	12.50	11.00	
6.0	25.00	14.00	14.00	14.00	11.80	10.80	
6.5	22.70	14.00	14.00	14.00	11.20	10.40	8.00
7.0	20.70	14.00	14.00	13.40	10.70	9.90	8.00
7.5	18.90	14.00	14.00	12.80	10.20	9.50	8.00
8.0	17.40	14.00	14.00	12.30	9.70	9.10	8.00
8.5	16.05	14.00	14.00	11.80	9.20	8.70	8.00
9.0	14.90	14.00	14.00	11.30	8.80	8.30	8.00
10.0		13.00	13.20	10.50	8.00	7.70	7.50
11.0		11.00	11.20	9.80	7.30	7.10	6.95
12.0		9.40	9.60	9.20	6.80	6.50	6.45
13.0		8.10	8.20	8.25	6.30	6.10	6.00
14.0		7.00	7.10	7.15	5.80	5.70	5.60
16.0		5.30	5.40	5.40	5.10	4.90	4.85
18.0			4.20	4.20	4.20	4.30	4.25
20.0			3.30	3.30	3.30	3.30	3.60
22.0				2.50	2.60	2.60	2.85
24.0					2.00	2.10	2.25
26.0					1.55	1.60	1.80
28.0						1.15	1.35
30.0						0.80	1.00
32.0							0.70
34.0							0.40

A = Boom length B = Working radius

[TELESCOPING METHOD b]

Unit : ton

Outriggers fully extended + Front jack (Over front)							
A \ B (m)	10.65 m	18.0 m	21.7 m	25.3 m	29.0 m	32.7 m	40.0 m
3.0	50.00	14.00					
3.5	43.00	14.00	14.00				
4.0	38.00	14.00	14.00	14.00			
4.5	34.00	14.00	14.00	14.00	14.00		
5.0	30.20	14.00	14.00	14.00	13.20		
5.5	27.50	14.00	14.00	14.00	12.50	11.00	
6.0	25.00	14.00	14.00	14.00	11.80	10.80	
6.5	22.70	14.00	14.00	14.00	11.20	10.40	8.00
7.0	20.70	14.00	14.00	13.40	10.70	9.90	8.00
7.5	18.90	14.00	14.00	12.80	10.20	9.50	8.00
8.0	17.30	14.00	14.00	12.30	9.70	9.10	8.00
8.5	15.50	14.00	14.00	11.80	9.20	8.70	8.00
9.0	13.90	14.00	14.00	11.30	8.80	8.30	8.00
10.0		12.20	12.40	10.50	8.00	7.70	7.50
11.0		10.25	10.40	9.80	7.30	7.10	6.95
12.0		8.80	8.95	9.05	6.80	6.50	6.45
13.0		7.60	7.75	7.85	6.30	6.10	6.00
14.0		6.60	6.75	6.85	5.80	5.70	5.60
16.0		5.05	5.20	5.30	5.10	4.90	4.85
18.0			4.10	4.20	4.20	4.25	4.25
20.0			3.20	3.30	3.30	3.30	3.40
22.0				2.50	2.60	2.60	2.75
24.0					2.00	2.10	2.15
26.0					1.55	1.60	1.70
28.0						1.15	1.30
30.0						0.80	1.00
32.0							0.70
34.0							0.40

A = Boom length B = Working radius

[TELESCOPING METHOD b]

Unit : ton

· Outriggers middle extended (360°) · Outriggers fully extended (Over front)							
A \ B (m)	10.65 m	18.0 m	21.7 m	25.3 m	29.0 m	32.7 m	40.0 m
3.0	40.00	14.00					
3.5	34.00	14.00	14.00				
4.0	28.60	14.00	14.00	14.00			
4.5	25.40	14.00	14.00	14.00	14.00		
5.0	19.10	14.00	14.00	14.00	13.20		
5.5	14.90	14.00	14.00	14.00	12.50	11.00	
6.0	12.10	13.10	13.40	14.00	11.80	10.80	
6.5	10.00	10.95	11.20	11.30	11.20	10.40	8.00
7.0	8.35	9.30	9.50	9.60	9.80	9.85	8.00
7.5	7.10	7.95	8.20	8.30	8.45	8.50	8.00
8.0	6.05	6.90	7.10	7.20	7.35	7.40	7.60
8.5	5.20	6.00	6.20	6.30	6.40	6.50	6.80
9.0	4.45	5.25	5.45	5.55	5.65	5.75	6.00
10.0		4.05	4.25	4.30	4.50	4.55	4.70
11.0		3.15	3.35	3.40	3.50	3.60	3.70
12.0		2.45	2.65	2.70	2.80	2.85	3.00
13.0		1.90	2.10	2.15	2.25	2.25	2.40

[TELESCOPING METHOD a, b]

Unit : ton

Without outriggers (Over rear)	
A \ B (m)	10.65 m
3.0	8.00
3.5	6.40
4.0	5.10
4.5	4.20
5.0	3.40
5.5	2.80
6.0	2.30
6.5	1.90
7.0	1.60
7.5	1.25
8.0	1.00

A = Boom length
 B = Working radius

[TELESCOPING METHOD a, b]

Unit : ton

· Outriggers fully extended + Front jack (360°) · Outriggers fully extended (Over rear · Over sides)						
C D E (°)	9.0 m			14.6 m		
	5°	25°	45°	5°	25°	45°
80	3.50	2.40	1.60	2.50	1.25	0.80
79	3.50	2.40	1.60	2.50	1.25	0.80
78	3.50	2.40	1.60	2.50	1.25	0.80
77	3.50	2.40	1.60	2.40	1.25	0.80
76	3.50	2.40	1.58	2.30	1.22	0.80
75	3.50	2.30	1.55	2.15	1.20	0.80
73	3.15	2.15	1.52	2.00	1.15	0.77
70	2.75	1.95	1.50	1.80	1.10	0.75
68	2.50	1.80	1.45	1.65	1.05	0.72
65	2.20	1.65	1.40	1.45	1.00	0.70
63	1.95	1.55	1.33	1.35	0.95	0.69
60	1.70	1.40	1.25	1.20	0.87	0.67
58	1.40	1.25	1.15	1.10	0.82	0.65
55	0.95	0.85	0.80	0.80	0.70	0.60
53	0.70	0.65	0.60	0.60	0.50	0.45
50	0.40	0.35	0.30	0.30		

[TELESCOPING METHOD a, b]

Unit : ton

· Outriggers middle extended (360°) · Outriggers fully extended (Over front)						
C D E (°)	9.0 m			14.6 m		
	5°	25°	45°	5°	25°	45°
80	3.50	2.40	1.60	2.50	1.25	0.80
79	3.50	2.40	1.60	2.50	1.25	0.80
78	3.40	2.40	1.60	2.50	1.25	0.80
77	2.90	2.15	1.60	2.40	1.25	0.80
76	2.40	1.80		2.00		

C = Jib length D = Jib offset E = Boom angle

NOTES:

1. The total **rated loads** shown are for the case when the outriggers are set horizontally on firm ground. The values above the bold lines are based on the crane strength while those below are based on the crane stability.
2. The weights of slings and hooks (460kg for a 50 ton capacity hook, 280kg for a 20 ton capacity hook and 100kg for a 4 ton capacity hook) are included in the total rated loads shown.
3. The total rated load is based on the actual working radius including the deflection of the boom.
4. The chart below shows the standard number of part lines for each boom length. The load per line should not exceed 4.17t for the main winch and 4.0t for the auxiliary winch.

R \ A	A							
	10.65m	18.0 m	21.7 m	25.3 m	29.0 m	32.7 m	40.0 m	J
a	1 2	7	—	5	—	4	4	1
b	1 2	7	5	5	4	4	4	1

A = Boom length J = Jib / Single top R = Telescoping method

5. As a rule, free-fall operations should be performed only when lowering the hook alone. If a hoisted load must be lowered by free-fall operation, the load must be kept below 1/5th of the total rated load (the load per line must be 0.85t or less for the main winch and 0.8t or less for the auxiliary winch) and sudden braking operations must be avoided. Free-fall operations should not be performed when the outriggers are not used.
6. The total rated load for the single top is equal to the total rated load for the boom and must not exceed 4.0t. However, when hooks, slings, etc. are attached to the boom, operations should be based on the total rated loads determined by subtracting the weights of the hook, slings, etc. attached to the boom from the total rated load of the boom.

WORKING RADIUS - LIFTING HEIGHT
 [TELESCOPING METHOD a]

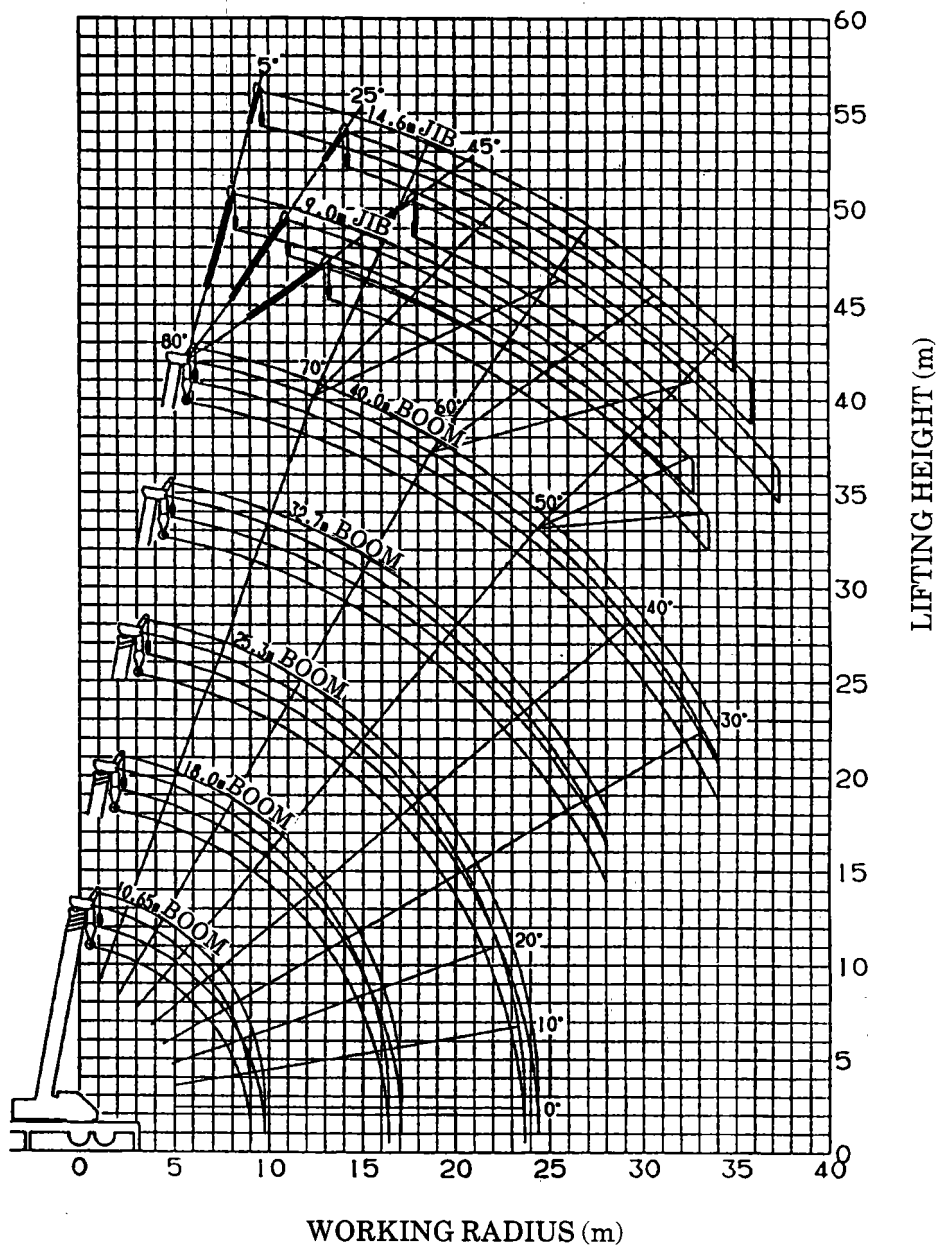

NOTES:

1. The deflection of the boom is not incorporated in the figure above.

[TELESCOPING METHOD b]

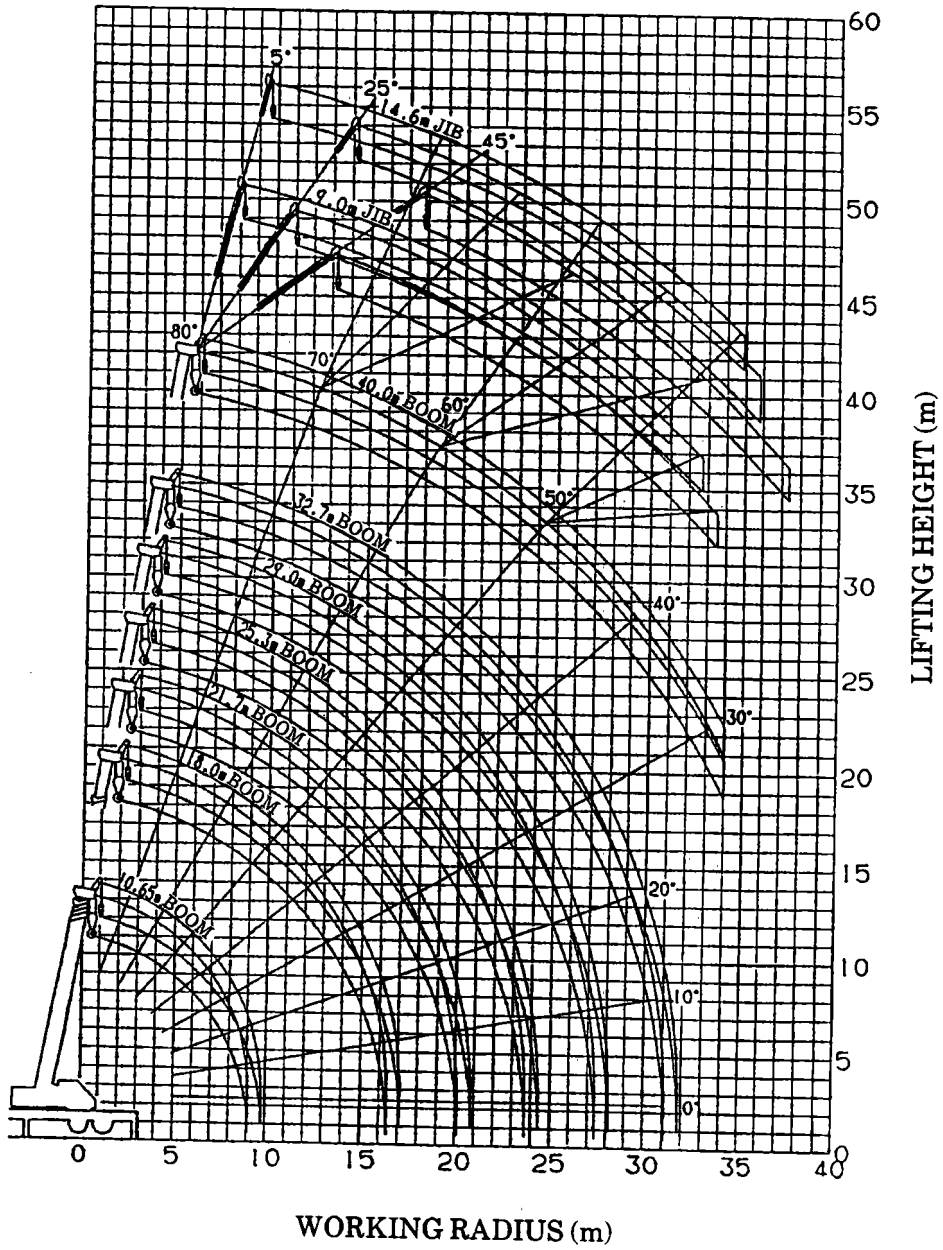

NOTES:

1. The deflection of the boom is not incorporated in the figure above.

DIMENSIONS (1/100)

W-KG520TN

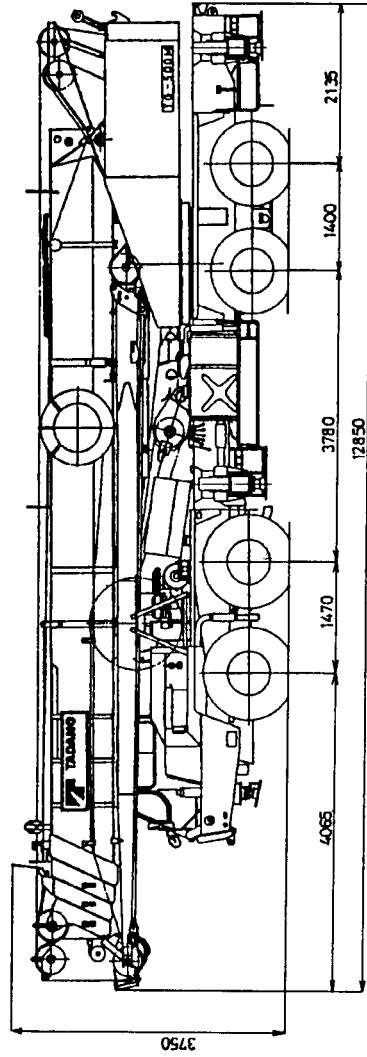
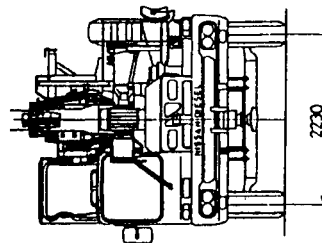
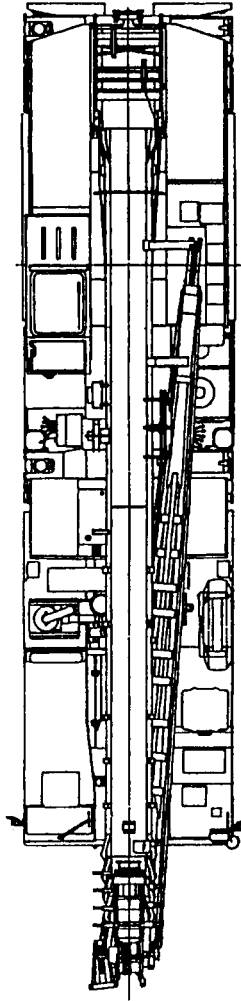
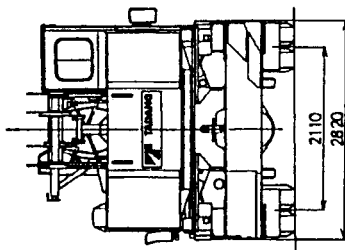

DIMENSIONS (1/100)
W-KS506S

