

## Hydraulic Crawler Crane

# 7035 Specifications

Max. lifting capacity: **35** metric tons at **3.7** m

Max. boom length: **39.62** m

Max. total length (boom + jib): **45.72** m

- Fast lifting and hoisting speeds ensure reduced cycle times on construction projects.
- Large-capacity drum permits clamshell work as deep as four floors down on the first cable layer.
- Heavy-duty hoisting capacity provided by high-output engine and 60-ton class winch.
- Power and stability to accommodate large vibrohammer attachments.
- Line pull of 16 tons makes sheet pile removal easy and quick
- Large-capacity brake drum with heat-radiating fin ensures safe seizure-free performance during continuous operation.

## General Dimensions

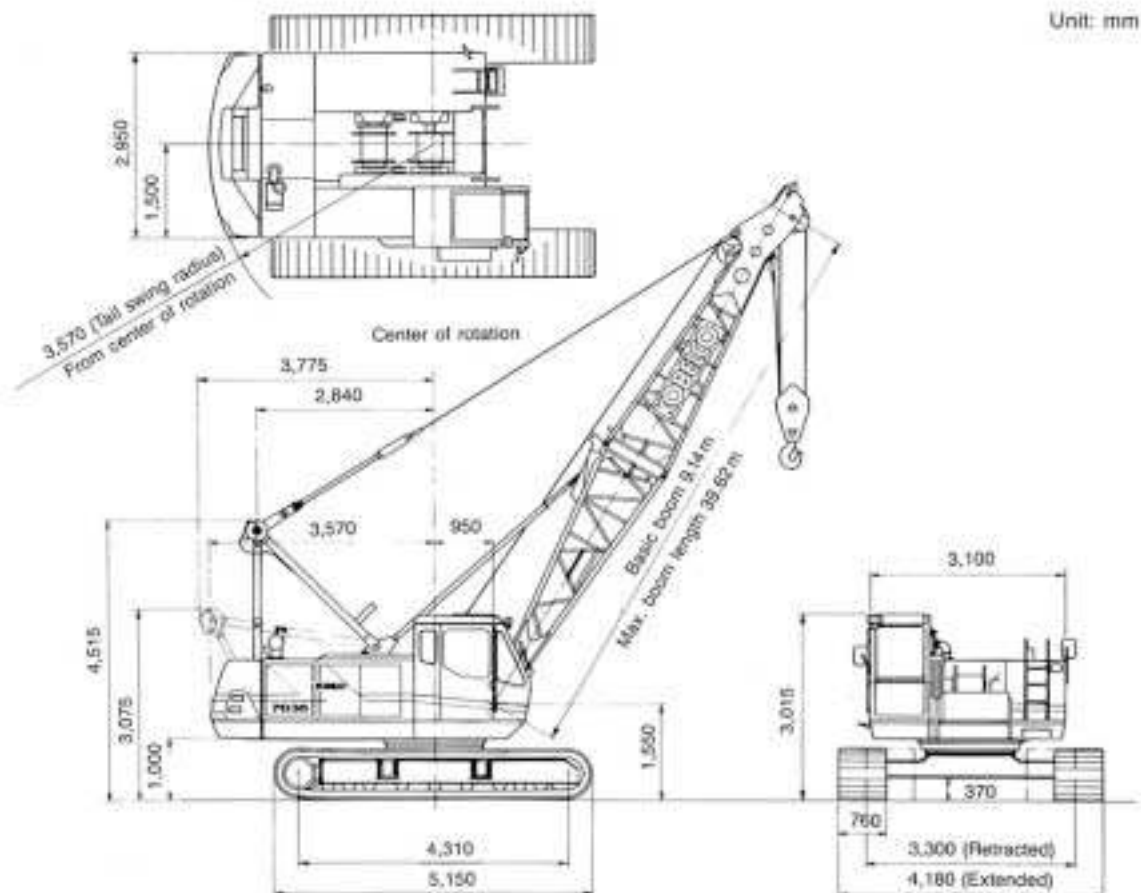

# Specifications

## UPPER MACHINERY



### Power Plant

Model	Mitsubishi 6D15T diesel
Type	Water cooled, direct fuel injection
No. of cylinders	6
Bore and stroke	113 mm x 115 mm
Displacement	6,919 liters
Rated power	155 PS (114 kW) at 2,150 rpm (DIN 6270)
Max. torque	58 kgf-m at 1,600 rpm (DIN 6270)
Cooling system	Liquid, recirculating bypass
Starter	24V, 4.5 kW
Generator	24V, 80 amp
Cycles	4
Radiator	Corrugated fin type core, thermostat controlled
Air cleaner	Two stage, dry
Fuel tank capacity	280 liters
Batteries	Two 12V, 150 A-hr capacity batteries, series connected
Fuel consumption	162 g/PS-h (at 1,200 rpm)



### Hydraulic System

**Pumps:** Three variable displacement plunger pumps and one gear pump are used. Two variable displacement plunger pumps are used in the propel circuits, boom hoist circuit, and hook hoist circuit. The other is used in the swing circuit and crawler extension circuit. The gear pump is used in the control system. Two plunger pumps are controlled by the Engine Speed Sensing (ESS) system, which automatically varied horsepower distribution according to work load. This system controls hydraulic oil flow and puts power where it's needed without wasting energy. The end result is highly efficient operation that utilizes 100% of engine's power.

**Control:** Horsepower summation hydraulic control system provides infinitely variable pressure to front and rear drums, boom, hoist brakes and clutches. Response to the operator's touch is instant, positive and smooth.

#### Pressure:

Load hoist, boom hoist and propel system	290 kg/cm <sup>2</sup>
Swing system	225 kg/cm <sup>2</sup>
Control system	105 kg/cm <sup>2</sup>
Hoist drum brake system	105 kg/cm <sup>2</sup>
Reservoir capacity	250 liters

**Cooling:** Oil-to-air heat exchanger, mounted in front of radiator.

**Filtration:** Suction strainer, in-line strainer, return filter, and drain filters



### Boom Hoisting System

Powered by a hydraulic axial piston motor through a planetary reducer.

**Brake:** Spring-set, hydraulically released

multiple-disk brake, mounted on the boom hoist motor and operated through a control valve.

**Drum lock:** Spring-set hydraulically released drum pawl, automatically actuated when boom is stopped.

**Drum:** One-piece cast drum, grooved for 14 mm dia. wire rope.

**Line speed (Single line on first drum layer):**

Hoisting (max.)	68 m/min
Lowering (max.)	68 m/min



### Load Hoist System

Tandem drums powered independently by two hydraulic axial piston motors through a planetary reducers.

**Clutches:** Internally expanding band clutches (splined on shaft).

**Brakes:** Brake valves and externally contracting, spring-set, hydraulically released band brakes with both positive and negative actuation.

**Drum locks:** Manual safety pawls (external ratchets).

**Drums (front and rear):** 420 mm P.C.Dg 430 mm wide drums, each grooved for 20 mm wire rope. Rope capacity of 158 m working length and 270 m storage length.

**Line speed (Single line on the first drum layer):**

High	70 m/min
Low	35 m/min



### Swing System

**Swing unit:** Independently powered by a hydraulic plunger motor through a planetary reducer; 360° of rotation.

**Max. swing speed:** 3.7 rpm

**Swing circle:** Single-row ball bearings with internal swing gear. Bolted to both upper structure and under-carriage.

**Swing lock:** Two-position pin-in-hole lock (manual)

**Brake:** Spring-set, hydraulically released multiple-disk brake, mounted on the swing motor.



### Operator's Cab

Totally enclosed, full-vision cab fitted with safety glass and a sliding front window. A fully adjustable, high-backed seat permits all operators to set ideal working position. Signal horn, cigarette lighter, ashtray, windshield wipers, washer, floor mat and cab heater are standard features.



### Controls

Response to the operator's touch is instant, positive, and smooth.

### Check and Safety Monitor

**Gauges:** Hourmeter, water temperature, fuel, and optional tachometer

**Warning lamps:** Charge, fuel level, control pressure, hydraulic oil temperature, water temperature, engine oil pressure, engine oil filter, CPU, and main hoist brake

switch

**Safety lamps:** Cooling water (subtank) level and engine oil level

**Lever locks:** Aux. drum control, boom control, main drum control, optional third drum control, and travel control

**Others:** Swing lock (pin) and Drum lock (pawl)

Optional load moment limiter (LCD) and CPU release switch

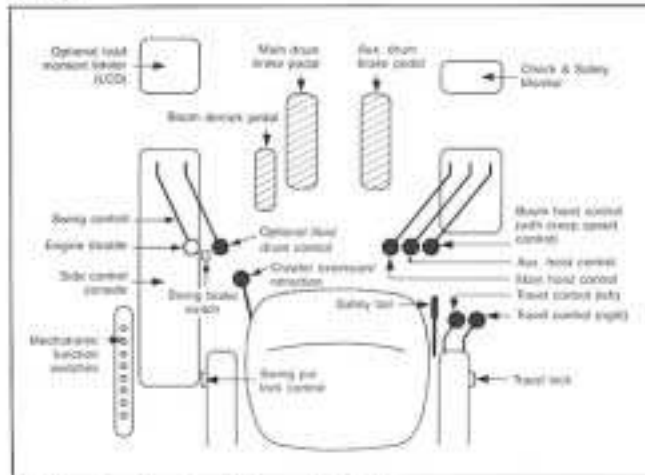

**Mechatronic functions include:**

**ESS (Engine Speed Sensing)** Ensures full use of engine power at all times.

**SensaTouch Control** Permits operator to "feel" the movement and weight of the load through the control lever.

**Inching Switch** Provides accurate and smooth swing, hoisting, and travel at low speed for bolt matching, pile placement, and other delicate operations.

**Note:** Please consult your local dealer for details concerning which features are standard and which are optional.



**Gantry**

Two-position, telescopic gantry, raised and lowered by boom hoist rope.

**Counterweight**

Three-piece mounted behind the machinery compartment.

Total weight ..... 10,900kg



**Tools**

Tool set and accessories for routine machine maintenance.

**LOWER MACHINERY**

**Carbody:** Steel-welded carbody with axles.

**Crawler:** Side frames can be hydraulically extended for wide-track operation or retracted for transportation.

Extension cylinders operated with a valve in the upper control system. Crawler belt tension adjusted with hydraulic jack and maintained by shims between idler block and frame.

**Crawler drive:** Independent hydraulic propel drive built into each side frame, each with a piston motor propelling a driving wheel through a planetary gear box.

**Crawler brakes:** Brake valves and spring-set, hydraulically released multiple-disc parking brakes.

**Steering mechanism:** Differential speed steering (driving one track faster than the other), counter-rotating steering (driving tracks in opposite directions) and skid steering (driving one track only) with lever control.

**Track rollers:** 9 lower rollers in each side frame, with life-time lubrication for maintenance-free operation.

**Shoes:** Track link type

Number ..... 60 each side

Standard flat shoe width ..... 760mm

Max. travel speed ..... 1.6 km/h

Max. gradeability ..... 40%

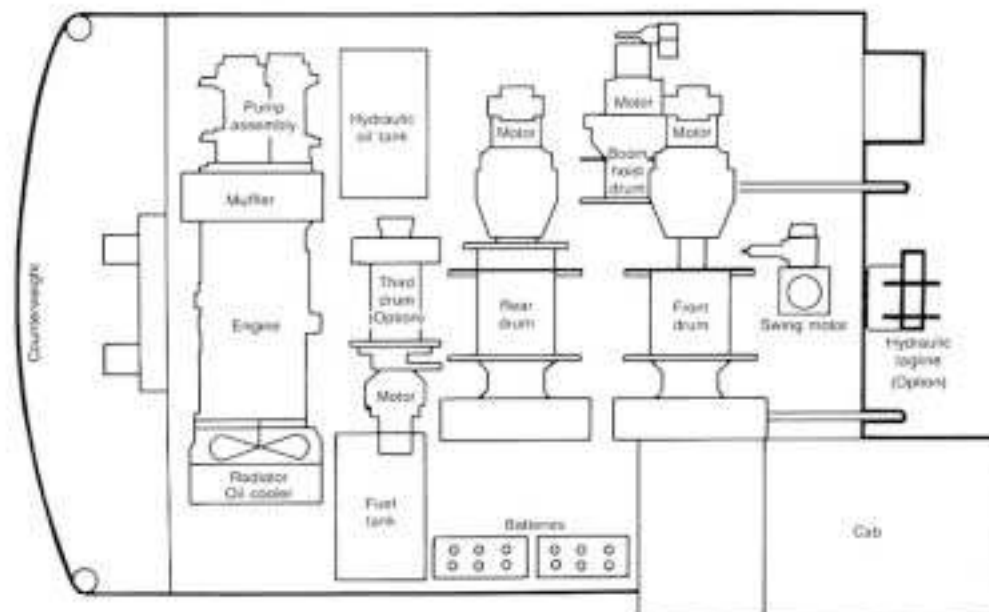

# Lifting Capacities

## CRANE ATTACHMENT



### Boom

Welded lattice construction using tubular, high tensile steel chords with pin connections between sections.

Max. lifting capacity	35 tons
Basic boom length	9.14 m
Max. boom length	39.62 m



### Jib (optional)

Welded lattice construction using tubular, high tensile steel chords with pin connections between sections.

Max. lifting capacity	5.5 tons
Max. jib length	12.19 m
Max. total length (Boom length + jib length)	39.53 m + 12.19 m



### Hook Blocks

Range of hook blocks can be specified, each with a safety latch.

Lifting capacity	35 tons	25 tons	15 tons	5.7 tons
No. of sheaves	3	2	1	0
Weight (kg)	320	300	300	120

## Diameter of wire ropes

Standard:

Hook hoist ..... 20 mm  
 Boom hoist (12-part line) ..... 14 mm  
 Boom pendants (2-part line) ..... 28 mm

Optional:

Jib hook hoist ..... 20 mm  
 Jib back stay pendants ..... 18 mm  
 Boom backstops recommended for all boom lengths.

## Weight

Working weight: Approx. 38,000 kg (including 9.14 m boom, 35 ton hook block and standard counterweights)  
 Ground pressure ..... 0.54 kg/cm<sup>2</sup>

## Line speed and line pull

		Max. line speed m/min		Max. running line pull
		Hoisting	Lowering	
Standard winches	Main hoist drum	H 70	L 70	16.0 tons
		L 35	L 35	
	Aux. hoist drum	H 70	L 70	16.0 tons
		L 35	L 35	

NOTE: 1. Line speed and line pull are based on the first layer of winding at rated engine rpm.  
 2. Hoisting line speed varies with load.  
 3. Line pull is based on a single line pull in high speed range.  
 4. After motor rotating, the line pull becomes "Max. running line pull" shortly.

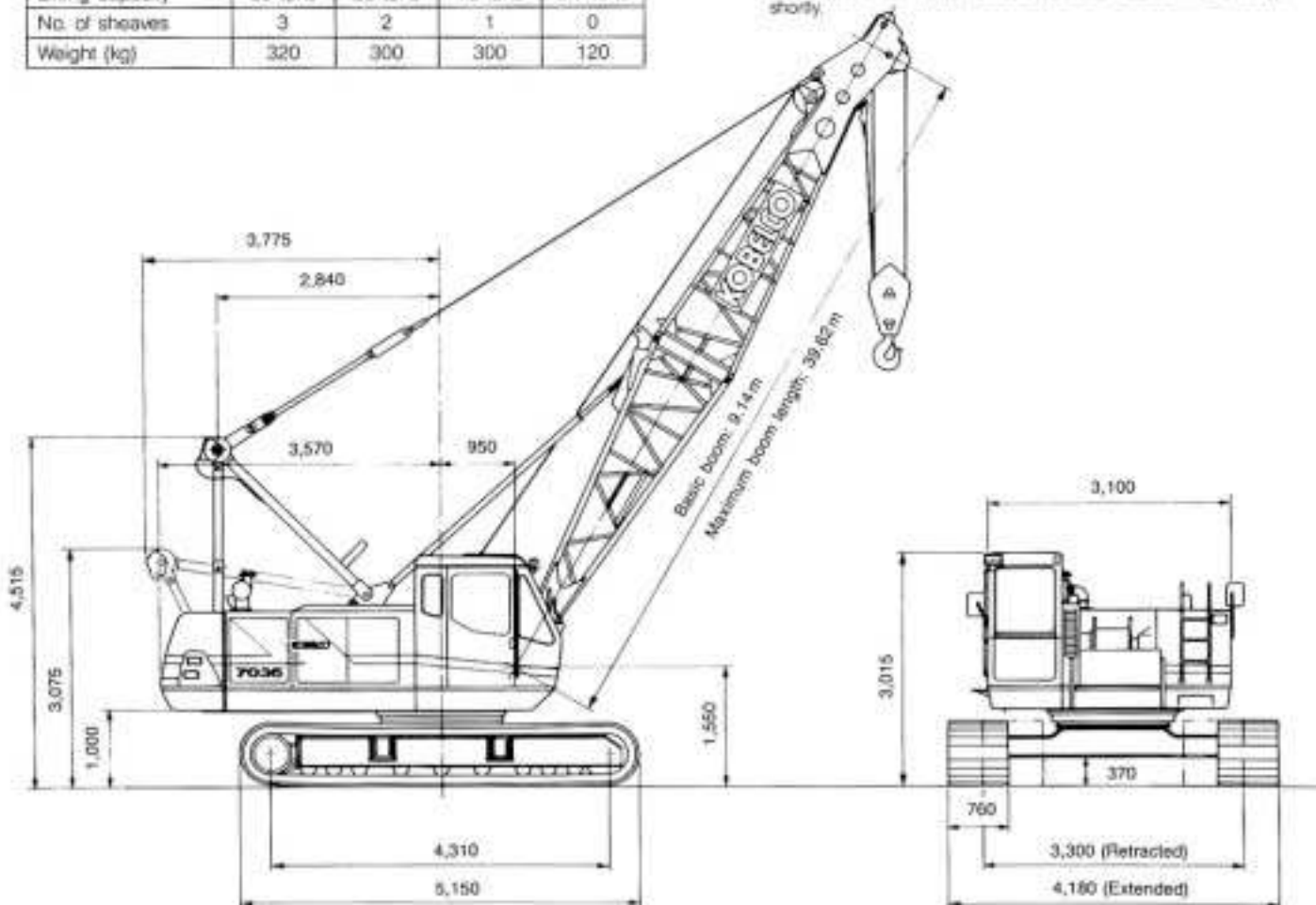

The following points should be kept in mind when interpreting the ratings given below.

1. Operating radius is the horizontal distance from center of rotation to the hoist load line or tackle with load applied.
2. Rated loads do not exceed 78% of tipping loads, and include weights of the load, hook blocks, slings and other lifting devices.
3. Rated loads are for stationary and level cranes lifting freely suspended loads, and have been determined for ideal operating conditions. The user must limit or de-rate rated loads to allow for adverse conditions (such as soft or uneven ground, out-of-level conditions, winds, side loads, pendulum action, jerking or sudden stopping of loads, inexperience of personnel, multiple machine lifts and traveling with a load.)
4. Rated loads apply only to upper, lower, boom, jib, auxiliary sheave, and 15,700 kg counterweight manufactured by Kobe Steel, Ltd.
5. Boom backstops are required for all boom lengths.
6. Gantry must be in fully raised position for all operations.
7. Crawlers must be fully extended and be locked in position.
8. The crane must be leveled to within 1% on a firm supporting surface.
9. When lifting over the boom point with a jib or auxiliary sheave, the combined weight of boom hook block, jib hook block, slings and other lifting devices is part of the total load. Their total weight must therefore be subtracted from the rated load to obtain the weight that can be lifted.
10. Boom lengths for jib mounting are 24.38 m to 33.53 m.
11. An auxiliary sheave cannot be used on a 39.62 m boom.
12. The boom should be erected over the front of the crawlers, not laterally.

## Working Ranges (with fixed jib)

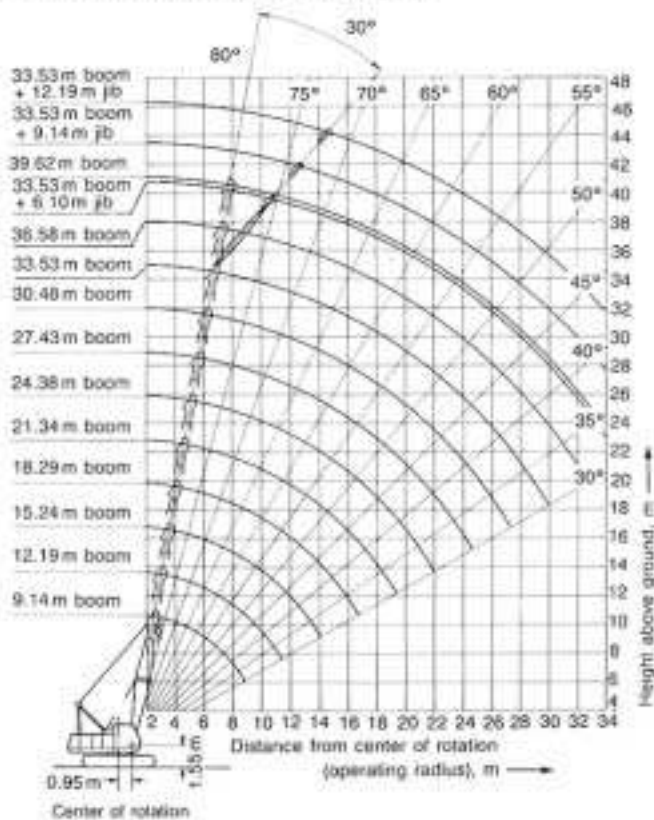

## Boom Make-up Arrangement

Boom length meters (ft)	Boom insert arrangement
9.14 (30)	Base-Tip
12.19 (40)	Base-A-Tip
15.24 (50)	Base-B-Tip
18.29 (60)	Base-A-B-Tip, Base-C-Tip
21.34 (70)	Base-B-B-Tip, Base-A-C-Tip
24.38 (80)	Base-A-B-B-Tip, Base-B-C-Tip
27.43 (90)	Base-B-B-B-Tip, Base-A-B-C-Tip
30.48 (100)	Base-A-B-B-B-Tip, Base-B-B-C-Tip
33.53 (110)	Base-A-B-B-C-Tip
36.58 (120)	Base-B-B-B-C-Tip
39.62 (130)	Base-A-B-B-B-C-Tip

Base=4.57m (15'), Tip=4.57m (15')

Inserts: A=3.05m (10'), B=6.10m (20'), C=9.14m (30')

# Boom Lifting Capacities

## Rated Loads in Metric Tons for 360° Working Area (for Light Duty)

Unit: ton

Operating radius (m)	Boom length m (ft)											Operating radius (m)
	9.14 (30)	12.19 (40)	15.24 (50)	18.29 (60)	21.34 (70)	24.38 (80)	27.43 (90)	30.48 (100)	33.53 (110)	36.58 (120)	39.62 (130)	
3	35.00	3.3m x 35.00										3
3.5	35.00	35.00										3.5
3.7	35.00	35.00										3.7
4	33.10	33.00	32.95	4.3m x 28.25								4
4.5	27.05	26.95	26.90	26.85	4.9m x 23.35							4.5
5	22.80	22.75	22.65	22.60	22.55	5.4m x 19.85						5
5.5	19.70	19.60	19.55	19.50	19.45	19.40	5.9m x 17.15					5.5
6	17.35	17.25	17.15	17.10	17.05	17.00	16.95	6.4m x 14.60				6
7	13.95	13.80	13.75	13.70	13.60	13.55	13.50	13.45	12.60	7.5m x 10.00		7
8	11.60	11.50	11.40	11.35	11.30	11.20	11.20	11.10	11.05	10.40	9.10	8
9	8.9m x 9.95	9.80	9.75	9.65	9.60	9.50	9.45	9.40	9.35	9.30	8.70	9
10		8.55	8.45	8.40	8.30	8.25	8.20	8.10	8.05	8.00	7.95	10
12		11.6m x 7.00	6.65	6.55	6.50	6.40	6.35	6.30	6.20	6.20	6.10	12
14			5.45	5.35	5.25	5.20	5.15	5.05	5.00	4.95	4.85	14
16			14.2m x 5.30	4.50	4.40	4.30	4.25	4.15	4.10	4.05	4.00	16
18				16.9m x 4.15	3.75	3.65	3.60	3.50	3.45	3.40	3.30	18
20					19.5m x 3.35	3.15	3.10	3.00	2.95	2.90	2.80	20
22						2.75	2.65	2.60	2.50	2.45	2.35	22
24						22.1m x 2.70	2.35	2.25	2.20	2.10	2.05	24
26							24.8m x 2.20	1.95	1.90	1.85	1.75	26
28								27.4m x 1.80	1.65	1.60	1.50	28
30									1.45	1.40	1.25	30
32									30.1m x 1.45	1.15	1.05	32
34										32.7m x 1.10	0.85	34

Ratings inside the heavy lines are governed by the strength of the boom or other structural components.

## Rated Loads in Metric Tons for 360° Working Area (for Heavy Duty)

Unit: ton

Operating radius (m)	Boom length m (ft)											Operating radius (m)
	9.14 (30)	12.19 (40)	15.24 (50)	18.29 (60)	21.34 (70)	24.38 (80)	27.43 (90)	30.48 (100)	33.53 (110)	36.58 (120)	39.62 (130)	
3	35.00	3.3m x 35.00										3
3.5	35.00	35.00										3.5
3.7	35.00	35.00										3.7
4	33.10	33.00	32.95	4.3m x 28.20								4
4.5	27.05	26.95	26.90	26.85	4.9m x 23.30							4.5
5	22.80	22.70	22.65	22.60	22.50	5.4m x 19.75						5
5.5	19.70	19.60	19.55	19.50	19.40	19.35	5.9m x 17.10					5.5
6	17.35	17.25	17.15	17.10	17.00	16.95	16.90	6.4m x 14.95				6
7	13.95	13.80	13.75	13.65	13.60	13.50	13.45	13.35	7.5m x 11.80	7.5m x 11.90		7
8	11.60	11.50	11.40	11.35	11.25	11.15	11.10	11.05	10.95	10.90	10.70	8
9	8.9m x 9.95	9.80	9.70	9.65	9.55	9.50	9.45	9.35	9.25	9.20	9.15	9
10		8.55	8.45	8.35	8.25	8.20	8.15	8.05	7.95	7.90	7.85	10
12		11.6m x 7.00	6.65	6.55	6.45	6.35	6.30	6.20	6.15	6.05	6.00	12
14			5.40	5.30	5.25	5.15	5.10	5.00	4.90	4.85	4.80	14
16			14.2m x 5.30	4.45	4.35	4.25	4.20	4.10	4.05	3.95	3.90	16
18				16.9m x 4.15	3.70	3.60	3.55	3.45	3.35	3.25	3.20	18
20					19.5m x 3.30	3.10	3.00	2.90	2.85	2.75	2.70	20
22						2.70	2.60	2.50	2.45	2.35	2.30	22
24						21.1m x 2.65	2.30	2.15	2.10	2.00	1.95	24
26							24.8m x 2.15	1.90	1.80	1.70	1.65	26
28								27.4m x 1.70	1.55	1.45	1.35	28
30									1.35	1.20	1.10	30
32									30.1m x 1.35	1.05	0.90	32
34										32.7m x 0.95	0.75	34

Ratings inside the heavy lines are governed by the strength of the boom or other structural components.

# Fixed Jib Lifting Capacities

## Jib Rated Loads in Metric Tons for 360° Working Area (for Light Duty)

Unit: ton

Operating radius (m)	Offset Angle 30°												Operating radius (m)
	Boom length m (ft)												
	24.38 (80)			27.43 (90)			30.48 (100)			33.53 (110)			
	Jib length m (ft)			Jib length m (ft)			Jib length m (ft)			Jib length m (ft)			
	6.10 (20)	9.14 (30)	12.19 (40)	6.10 (20)	9.14 (30)	12.19 (40)	6.10 (20)	9.14 (30)	12.19 (40)	6.10 (20)	9.14 (30)	12.19 (40)	
11	4.50			4.50			4.50						11
12	4.50	4.10		4.50	4.10		4.50			4.50			12
14	4.50	4.10	3.20	4.50	4.10	3.20	4.50	4.10		4.50	4.10		14
16	4.45	4.10	3.20	4.40	4.10	3.20	4.35	4.10	3.20	4.30	4.10	3.20	16
18	3.70	3.90	3.20	3.65	3.80	3.20	3.80	3.75	3.20	3.55	3.70	3.20	18
20	3.15	3.30	3.20	3.05	3.20	3.20	3.00	3.15	3.20	2.95	3.10	3.20	20
22	2.65	2.80	2.90	2.60	2.75	2.85	2.55	2.65	2.80	2.50	2.60	2.75	22
24	2.25	2.40	2.50	2.20	2.35	2.45	2.15	2.25	2.40	2.05	2.20	2.35	24
26	1.95	2.05	2.15	1.85	2.00	2.10	1.75	1.90	2.05	1.70	1.85	2.00	26
28	1.60	1.75	1.85	1.50	1.65	1.80	1.45	1.60	1.70	1.35	1.50	1.65	28
30		1.45	1.60	1.25	1.40	1.50	1.15	1.30	1.40	1.10	1.25	1.35	30
32			1.30		1.15	1.25	0.90	1.05	1.15	0.85	1.00	1.10	32

Ratings inside the heavy lines are governed by the strength of the boom or other structural components.

## Jib Rated Loads in Metric Tons for 360° Working Area (for Heavy Duty)

Unit: ton

Operating radius (m)	Offset Angle 30°												Operating radius (m)
	Boom length m (ft)												
	24.38 (80)			27.43 (90)			30.48 (100)			33.53 (110)			
	Jib length m (ft)			Jib length m (ft)			Jib length m (ft)			Jib length m (ft)			
	6.10 (20)	9.14 (30)	12.19 (40)	6.10 (20)	9.14 (30)	12.19 (40)	6.10 (20)	9.14 (30)	12.19 (40)	6.10 (20)	9.14 (30)	12.19 (40)	
11	4.50			4.50			4.50						11
12	4.50	4.10		4.50	4.10		4.50			4.50			12
14	4.50	4.10	3.20	4.50	4.10	3.20	4.50	4.10		4.50	4.10		14
16	4.45	4.10	3.20	4.35	4.10	3.20	4.30	4.10	3.20	4.25	4.10	3.20	16
18	3.70	3.85	3.20	3.60	3.80	3.20	3.55	3.75	3.20	3.50	3.70	3.20	18
20	3.10	3.25	3.20	3.05	3.20	3.20	2.95	3.10	3.20	2.90	3.05	3.20	20
22	2.60	2.75	2.90	2.55	2.70	2.80	2.50	2.65	2.75	2.45	2.60	2.70	22
24	2.25	2.35	2.45	2.15	2.30	2.40	2.05	2.25	2.35	2.00	2.15	2.30	24
26	1.85	2.05	2.15	1.80	1.95	2.05	1.70	1.85	2.00	1.60	1.80	1.90	26
28	1.55	1.70	1.85	1.45	1.60	1.75	1.35	1.50	1.65	1.30	1.45	1.60	28
30		1.40	1.55	1.20	1.35	1.45	1.10	1.25	1.35	1.00	1.15	1.30	30
32			1.30		1.10	1.20	0.85	1.00	1.10	0.75	0.90	1.05	32

Ratings inside the heavy lines are governed by the strength of the boom or other structural components.

# Auxiliary Sheave Lifting Capacities

## Rated Loads in Metric Tons for 360° Working Area (for Light Duty)

Unit: ton

Operating radius (m)	Boom length in (ft)										Operating radius (m)	
	9.14 (30)	12.19 (40)	15.24 (50)	18.29 (60)	21.34 (70)	24.38 (80)	27.43 (90)	30.48 (100)	33.53 (110)	36.58 (120)		
3.5	5.70											3.5
3.7	5.70											3.7
4.0	5.70	5.70	5.70									4.0
4.5	5.70	5.70	5.70									4.5
5.0	5.70	5.70	5.70	5.70								5.0
5.5	5.70	5.70	5.70	5.70	5.70							5.5
6.0	5.70	5.70	5.70	5.70	5.70	5.70	6.5m x 5.70					6.0
7.0	5.70	5.70	5.70	5.70	5.70	5.70	5.70	5.70	7.5m x 5.70			7.0
8.0	5.70	5.70	5.70	5.70	5.70	5.70	5.70	5.70	5.70	5.70	5.70	8.0
9.0	8.9m x 5.70	5.70	5.70	5.70	5.70	5.70	5.70	5.70	5.70	5.70	5.70	9.0
10.0		5.70	5.70	5.70	5.70	5.70	5.70	5.70	5.70	5.70	5.70	10.0
12.0		11.6m x 5.70	5.70	5.70	5.70	5.70	5.70	5.70	5.70	5.70	5.70	12.0
14.0			5.30	5.20	5.10	5.05	5.00	4.90	4.85	4.80	4.80	14.0
16.0			14.2m x 5.15	4.35	4.25	4.15	4.10	4.00	3.95	3.90	3.90	16.0
18.0				16.9m x 4.00	3.60	3.50	3.45	3.35	3.30	3.25	3.25	18.0
20.0					19.5m x 3.20	3.00	2.95	2.85	2.80	2.75	2.75	20.0
22.0						2.60	2.50	2.45	2.35	2.30	2.30	22.0
24.0							22.1m x 2.55	2.20	2.10	2.05	1.95	24.0
26.0								24.8m x 2.05	1.80	1.75	1.70	26.0
28.0									27.4m x 1.65	1.50	1.45	28.0
30.0										1.30	1.25	30.0
32.0										30.1m x 1.30	1.00	32.0
34.0											32.7m x 0.95	34.0

Ratings inside the heavy lines are governed by the strength of the boom or other structural components.

## Rated Loads in Metric Tons for 360° Working Area (for Heavy Duty)

Unit: ton

Operating radius (m)	Boom length in (ft)										Operating radius (m)	
	9.14 (30)	12.19 (40)	15.24 (50)	18.29 (60)	21.34 (70)	24.38 (80)	27.43 (90)	30.48 (100)	33.53 (110)	36.58 (120)		
3.5	5.70											3.5
3.7	5.70											3.7
4.0	5.70	5.70	5.70									4.0
4.5	5.70	5.70	5.70									4.5
5.0	5.70	5.70	5.70	5.70								5.0
5.5	5.70	5.70	5.70	5.70	5.70							5.5
6.0	5.70	5.70	5.70	5.70	5.70	5.70	6.5m x 5.70					6.0
7.0	5.70	5.70	5.70	5.70	5.70	5.70	5.70	5.70	7.5m x 5.70			7.0
8.0	5.70	5.70	5.70	5.70	5.70	5.70	5.70	5.70	5.70	5.70	5.70	8.0
9.0	8.9m x 5.70	5.70	5.70	5.70	5.70	5.70	5.70	5.70	5.70	5.70	5.70	9.0
10.0		5.70	5.70	5.70	5.70	5.70	5.70	5.70	5.70	5.70	5.70	10.0
12.0		11.6m x 5.70	5.70	5.70	5.70	5.70	5.70	5.70	5.70	5.70	5.70	12.0
14.0			5.25	5.15	5.10	5.00	4.95	4.85	4.75	4.70	4.70	14.0
16.0			14.2m x 5.15	4.30	4.20	4.10	4.05	3.95	3.90	3.80	3.80	16.0
18.0				16.9m x 4.00	3.55	3.45	3.40	3.30	3.20	3.10	3.10	18.0
20.0					19.5m x 3.15	2.95	2.85	2.75	2.70	2.60	2.60	20.0
22.0						2.55	2.45	2.35	2.30	2.20	2.20	22.0
24.0							22.1m x 2.50	2.15	2.00	1.95	1.85	24.0
26.0								24.8m x 2.00	1.75	1.65	1.55	26.0
28.0									27.4m x 1.55	1.40	1.30	28.0
30.0										1.20	1.05	30.0
32.0										30.1m x 1.20	0.90	32.0
34.0											32.7m x 0.80	34.0

Ratings inside the heavy lines are governed by the strength of the boom or other structural components.



# Boom Lifting Capacities with Jib

## Rated Loads in Metric Tons for 360° Working Area (for Light Duty)

Unit: ton

Operating radius (m)	Boom length m (ft)												Operating radius (m)
	24.38 (80)			27.43 (90)			30.48 (100)			33.53 (110)			
	Jib length m (ft)			Jib length m (ft)			Jib length m (ft)			Jib length m (ft)			
6.10 (20)	9.14 (30)	12.19 (40)	6.10 (20)	9.14 (30)	12.19 (40)	6.10 (20)	9.14 (30)	12.19 (40)	6.10 (20)	9.14 (30)	12.19 (40)		
5.0	5.4 m × 19.05	5.4 m × 18.95	5.4 m × 18.85										5.0
5.5	18.80	18.50	18.40	5.9 m × 16.35	5.9 m × 16.25	5.9 m × 16.15							5.5
6.0	16.20	16.10	16.00	16.15	16.05	15.95	5.4 m × 13.90	6.4 m × 13.70	6.4 m × 13.60				6.0
7.0	12.75	12.65	12.55	12.70	12.60	12.50	12.65	12.55	12.45	11.80	11.70	11.60	7.0
8.0	10.40	10.30	10.20	10.40	10.30	10.20	10.30	10.20	10.10	10.25	10.15	10.05	8.0
9.0	8.70	8.60	8.50	8.65	8.55	8.45	8.60	8.50	8.40	8.55	8.44	8.35	9.0
10.0	7.45	7.35	7.25	7.40	7.30	7.20	7.30	7.20	7.10	7.25	7.15	7.05	10.0
12.0	5.60	5.50	5.40	5.55	5.45	5.35	5.50	5.40	5.30	5.40	5.30	5.20	12.0
14.0	4.40	4.30	4.20	4.35	4.25	4.15	4.25	4.15	4.05	4.20	4.10	4.00	14.0
16.0	3.50	3.40	3.30	3.45	3.35	3.25	3.35	3.25	3.15	3.30	3.20	3.10	16.0
18.0	2.85	2.75	2.65	2.80	2.70	2.60	2.70	2.65	2.55	2.65	2.55	2.45	18.0
20.0	2.35	2.25	2.15	2.30	2.20	2.10	2.20	2.10	2.00	2.15	2.05	1.95	20.0
22.0	1.95	1.85	1.75	1.85	1.75	1.65	1.80	1.70	1.60	1.70	1.60	1.50	22.0
24.0	22.1 m × 1.90	22.1 m × 1.80	22.1 m × 1.70	1.55	1.45	1.35	1.45	1.35	1.25	1.40	1.30	1.20	24.0

Ratings inside the heavy lines are governed by the strength of the boom or other structural components.

## Rated Loads in Metric Tons for 360° Working Area (for Heavy Duty)

Unit: ton

Operating radius (m)	Boom length m (ft)												Operating radius (m)
	24.38 (80)			27.43 (90)			30.48 (100)			33.53 (110)			
	Jib length m (ft)			Jib length m (ft)			Jib length m (ft)			Jib length m (ft)			
6.10 (20)	9.14 (30)	12.19 (40)	6.10 (20)	9.14 (30)	12.19 (40)	6.10 (20)	9.14 (30)	12.19 (40)	6.10 (20)	9.14 (30)	12.19 (40)		
5.0	5.4 m × 18.95	5.4 m × 18.85	5.4 m × 18.75										5.0
5.5	18.55	18.45	18.35	5.9 m × 16.30	5.9 m × 16.20	5.9 m × 16.10							5.5
6.0	16.15	16.05	15.95	16.10	16.00	15.90	6.4 m × 14.15	6.4 m × 14.05	6.4 m × 13.95				6.0
7.0	12.70	12.60	12.50	12.65	12.55	12.45	12.55	12.45	12.35	12.45	12.35	12.25	7.0
8.0	10.35	10.25	10.15	10.30	10.20	10.10	10.25	10.15	10.05	10.15	10.05	9.95	8.0
9.0	8.70	8.60	8.50	8.65	8.55	8.45	8.55	8.45	8.35	8.45	8.35	8.25	9.0
10.0	7.40	7.30	7.20	7.35	7.25	7.15	7.25	7.15	7.05	7.15	7.05	6.95	10.0
12.0	5.55	5.45	5.35	5.50	5.40	5.30	5.40	5.30	5.20	5.35	5.25	5.15	12.0
14.0	4.35	4.25	4.15	4.30	4.20	4.10	4.20	4.10	4.00	4.10	4.00	3.90	14.0
16.0	3.45	3.35	3.25	3.40	3.30	3.20	3.30	3.20	3.10	3.25	3.15	3.05	16.0
18.0	2.80	2.70	2.60	2.75	2.65	2.55	2.65	2.55	2.45	2.55	2.45	2.35	18.0
20.0	2.30	2.20	2.10	2.20	2.10	2.00	2.10	2.00	1.90	2.05	1.95	1.85	20.0
22.0	1.90	1.80	1.70	1.80	1.70	1.60	1.70	1.60	1.50	1.65	1.55	1.45	22.0
24.0	22.1 m × 1.85	22.1 m × 1.75	22.1 m × 1.65	1.50	1.40	1.30	1.35	1.25	1.15	1.30	1.20	1.10	24.0

Ratings inside the heavy lines are governed by the strength of the boom or other structural components.

# Boom Lifting Capacities with Auxiliary Sheave

## Rated Loads in Metric Tons for 360° Working Area (for Light Duty)

Unit: ton

Operating radius (m)	Boom length m (ft)										Operating radius (m)
	9.14 (30)	12.19 (40)	15.24 (50)	18.29 (60)	21.34 (70)	24.38 (80)	27.43 (90)	30.48 (100)	33.53 (110)	36.58 (120)	
3.0	34.85	3.3m x 34.85									3.0
3.5	34.85	34.85									3.5
3.7	34.85	34.85									3.7
4.0	32.95	32.90	32.80	4.3m x 28.10							4.0
4.5	26.90	26.80	26.75	26.70	4.9m x 23.20						4.5
5.0	22.65	22.60	22.50	22.45	22.40	5.4m x 19.70					5.0
5.5	19.55	19.45	19.40	19.35	19.30	19.25	5.9m x 17.00				5.5
6.0	17.20	17.10	17.00	16.95	16.90	16.85	16.80	6.4m x 14.45			6.0
7.0	13.80	13.65	13.60	13.55	13.45	13.40	13.35	13.30	12.45	7.5m x 10.45	7.0
8.0	11.45	11.35	11.25	11.20	11.15	11.05	11.05	10.95	10.90	10.25	8.0
9.0	8.9m x 9.80	9.65	9.60	9.50	9.45	9.35	9.30	9.25	9.20	9.15	9.0
10.0		8.40	8.30	8.25	8.15	8.10	8.05	7.95	7.90	7.85	10.0
12.0		11.6m x 6.85	6.50	6.40	6.35	6.25	6.20	6.15	6.05	6.05	12.0
14.0			5.30	5.20	5.10	5.05	5.00	4.90	4.85	4.80	14.0
16.0			14.2m x 5.15	4.35	4.25	4.15	4.10	4.00	3.95	3.90	16.0
18.0				16.9m x 4.00	3.60	3.50	3.45	3.35	3.30	3.25	18.0
20.0					19.5m x 3.20	3.00	2.95	2.85	2.80	2.75	20.0
22.0						2.60	2.50	2.45	2.35	2.30	22.0
24.0						22.1m x 2.55	2.20	2.10	2.05	1.95	24.0
26.0							24.8m x 2.05	1.80	1.75	1.70	26.0
28.0								27.4m x 1.65	1.50	1.45	28.0
30.0									1.30	1.25	30.0
32.0									30.1m x 1.30	1.00	32.0
34.0										32.7m x 0.95	34.0

Ratings inside the heavy lines are governed by the strength of the boom or other structural components.

## Rated Loads in Metric Tons for 360° Working Area (for Heavy Duty)

Unit: ton

Operating radius (m)	Boom length m (ft)										Operating radius (m)
	9.14 (30)	12.19 (40)	15.24 (50)	18.29 (60)	21.34 (70)	24.38 (80)	27.43 (90)	30.48 (100)	33.53 (110)	36.58 (120)	
3.0	34.85	3.3m x 34.85									3.0
3.5	34.85	34.85									3.5
3.7	34.85	34.85									3.7
4.0	32.95	32.85	32.80	4.3m x 28.05							4.0
4.5	26.90	26.80	26.75	26.70	4.9m x 23.15						4.5
5.0	22.65	22.55	22.50	22.45	22.35	5.4m x 19.80					5.0
5.5	19.55	19.45	19.40	19.35	19.25	19.20	5.9m x 16.95				5.5
6.0	17.20	17.10	17.00	16.95	16.85	16.80	16.75	6.4m x 14.80			6.0
7.0	13.80	13.65	13.60	13.50	13.45	13.35	13.30	13.20	13.10	7.5m x 11.75	7.0
8.0	11.45	11.35	11.25	11.20	11.10	11.00	10.95	10.80	10.80	10.75	8.0
9.0	8.9m x 9.80	9.65	9.55	9.50	9.40	9.35	9.30	9.20	9.10	9.05	9.0
10.0		8.40	8.30	8.20	8.10	8.05	8.00	7.90	7.80	7.75	10.0
12.0		11.6m x 6.85	6.50	6.40	6.30	6.20	6.15	6.05	6.00	5.90	12.0
14.0			5.25	5.15	5.10	5.00	4.95	4.85	4.75	4.70	14.0
16.0			14.2m x 5.15	4.30	4.20	4.10	4.05	3.95	3.90	3.80	16.0
18.0				16.9m x 4.00	3.55	3.45	3.40	3.30	3.20	3.10	18.0
20.0					19.5m x 3.15	2.95	2.85	2.75	2.70	2.60	20.0
22.0						2.55	2.45	2.35	2.30	2.20	22.0
24.0						22.1m x 2.50	2.15	2.00	1.75	1.85	24.0
26.0							24.8m x 2.00	1.75	1.65	1.55	26.0
28.0								27.4m x 1.55	1.40	1.30	28.0
30.0									1.20	1.05	30.0

Ratings inside the heavy lines are governed by the strength of the boom or other structural components.

# Clamshell



## Boom

Welded lattice construction using tubular, high tensile steel chords with pin connections between sections. Two types of boom are available: one for all-purpose operation and one for clamshell operation only.

Basic boom length ..... 9.14m

Max. boom length ..... 18.29m

Open throat with offset boom point sheaves on anti-friction bearing, bottom diameter ..... 0.4m

Std. boom hoist reeving ..... 12-part line

Tagline: Hydraulic operated type  
(optional spring type)

## Boom Make-up Arrangement

Boom length (m)	Boom insert arrangement
12.19	Base-A-Tip
15.24	Base-B-Tip
18.29	Base-A-B-Tip

Base = 4.57m Tip = 4.57m Inserts: A = 3.05m, B = 6.10m

## Clamshell Buckets

Capacity (m <sup>3</sup> )	Approximate weight (kg)	T-Bucket clearance (m)
0.6	1,600	3.0
0.8	2,100	3.3
1.0	2,100	3.3
1.2	2,100	3.7

### Notes:

- 1) Bucket weight must not exceed 2.1 tons only
- 2) The 1.2m<sup>3</sup> bucket is for loading operations.
- 3) Clamshell ratings also apply to grapple and all other material-handling buckets except dragline
- 4) For clamshell operations, bucket weight is considered part of the load and the total bucket weight plus contents must not exceed the corresponding ratings shown.
- 5) Ratings assume the use of a KOBELCO boom.
- 6) Limit on clamshell rating: 5 tons.

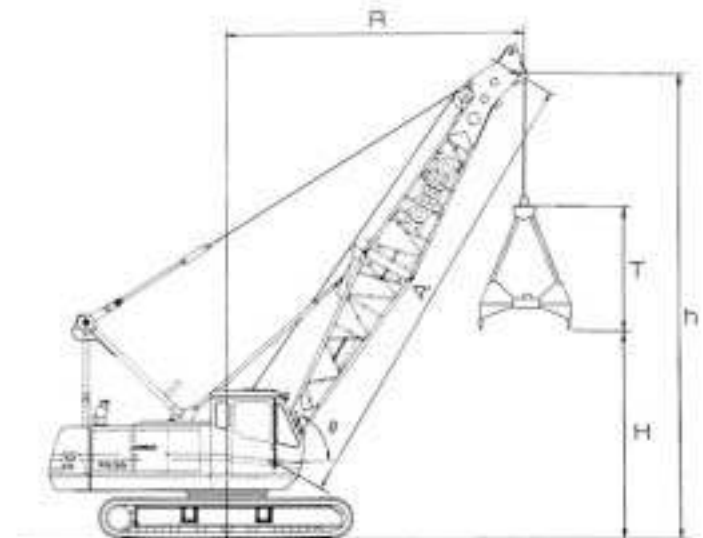

## Clamshell Ratings and Working Ranges

A	Boom length (m)	9.14				12.19				15.24				18.29					
		35°	45°	55°	65°	35°	45°	55°	65°	35°	45°	55°	65°	35°	45°	55°	65°		
θ	Boom angle (°)	35°	45°	55°	65°	35°	45°	55°	65°	35°	45°	55°	65°	35°	45°	55°	65°		
R	Working radius (m)	8.8	7.8	6.6	5.2	11.3	9.9	8.3	6.5	14.0	12.1	10.1	7.8	16.0	14.0	11.8	9.1		
H	Height at bucket opening	Bucket capacity	0.6m <sup>3</sup>	1.1	2.3	3.4	4.2	2.8	4.5	5.9	7.0	4.6	6.6	8.4	9.7	6.3	8.8	10.9	12.5
			0.8m <sup>3</sup>	0.8	2.0	3.1	3.9	2.5	4.2	5.6	6.7	4.3	6.3	8.1	9.4	6.0	8.5	10.6	12.2
			1.0m <sup>3</sup>	0.8	2.0	3.1	3.9	2.5	4.2	5.6	6.7	4.3	6.3	8.1	9.4	6.0	8.5	10.6	12.2
			1.2m <sup>3</sup>	0.4	1.6	2.7	3.5	2.1	3.8	5.2	6.3	3.9	5.9	7.7	9.0	5.6	8.1	10.2	11.8
h	Boom point height (m)	6.6	7.8	8.9	9.7	8.3	10.0	11.4	12.5	10.1	12.1	13.9	15.2	11.8	14.3	16.4	18.0		
	Rated loads (ton)	5.0				5.0				4.6				5.0					

# Vibrohammer

## ■ Load limitations

1. The total weight of the hook, pile, and vibrohammer must not exceed the crane's rated load capacity.
2. The total weight of the hook, pile, and vibrohammer, plus 25% of the centrifugal force of the vibrohammer, must not exceed the crane's rated load capacity.

## ■ The following points should be kept in mind when interpreting the ratings given below.

1. Maximum boom length is 24.38m (80 ft).
2. Boom angle should be kept between 60 and 70 degrees during operation.

3. Hook must be large enough to accommodate the centrifugal force of the vibrohammer.
4. Do not connect the vibrohammer directly to the hook. Always use a cable that has a safety factor of 6 or more.
5. Do not attempt to extract piles solely by means of the crane hoist. Always engage the vibrohammer.
6. Adjust extraction force according to the condition of the buffer spring. The more compressed the spring, the less force should be applied.
7. Maximum horsepower for different types of vibrohammers should be set as follows:  
Standard or noise-reduction and vibration-isolation types: 60 HP  
Variable high-frequency types: 40 HP

## Recommended Hook and Cable Specifications

Centrifugal force of vibrohammer (tons)	Hook blocks (ton)	Lifting cable (mm)
To 15	15	Two or more parts; 20mm diameter
16-25	25	Four or more parts; 20mm diameter
26-35	35	Four or more parts; 20mm diameter
36-45	45	Six or more parts; 20mm diameter

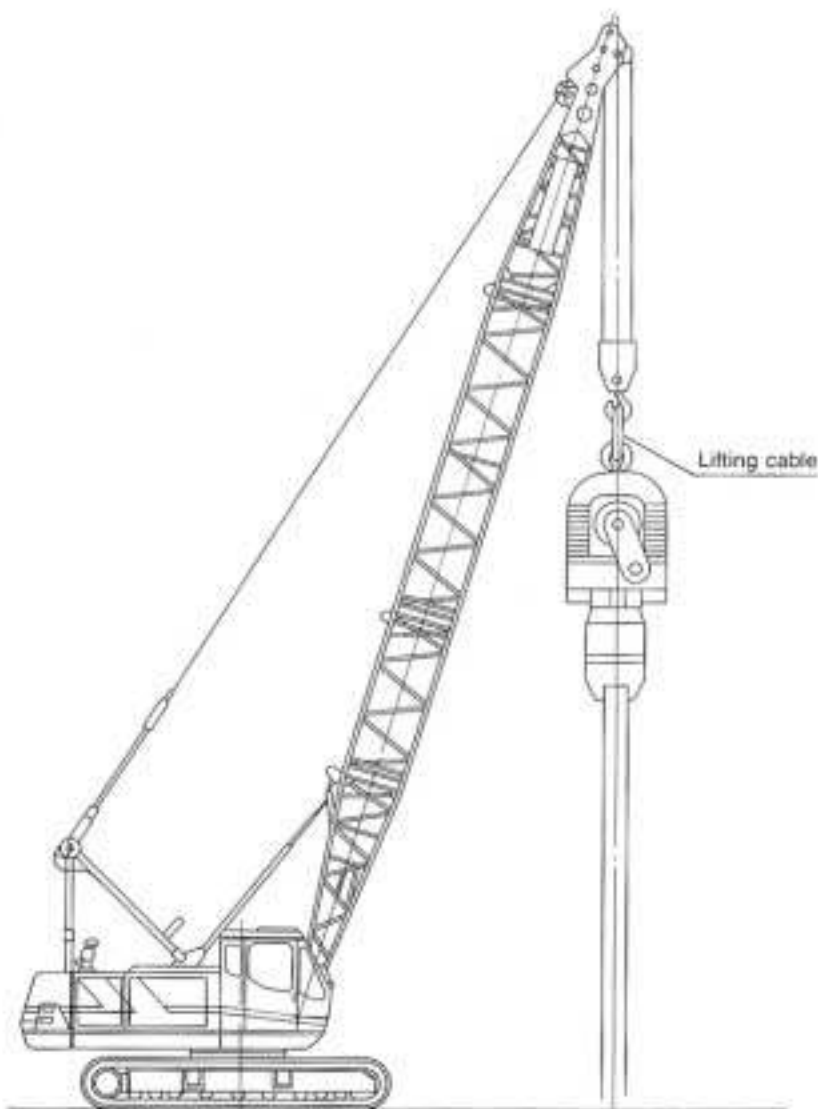

# Lifting Magnet



## Boom

Welded lattice construction using tubular, high tensile steel chords with pin connections between sections.

Basic boom length ..... 9.14 m  
 Max. boom length ..... 18.29 m  
 Open throat with offset boom point sheaves on anti-friction bearing, bottom diameter ..... 0.4 m  
 Std. boom hoist reeving ..... 12-part line

## Lifting Magnet

Model		LMCH-130 HA-6	LMCH-150 HA-6
Diameter	mm	1,300	1,500
Weight	kg	2,100	2,750
Voltage	V	DC 220	
Generator capacity	kW	15	20
Boom length	m (ft)	9.14 (30)-18.29 (60)	
Operating radius	m	6.0-18.0	
Operating weight with 9.14 m boom	ton	40.0	40.6
Ground pressure	kg/cm <sup>2</sup>	0.57	0.58

### Notes:

1. Ratings do not exceed 90% of crane ratings.
2. All specifications are based on the machine's internal power source.

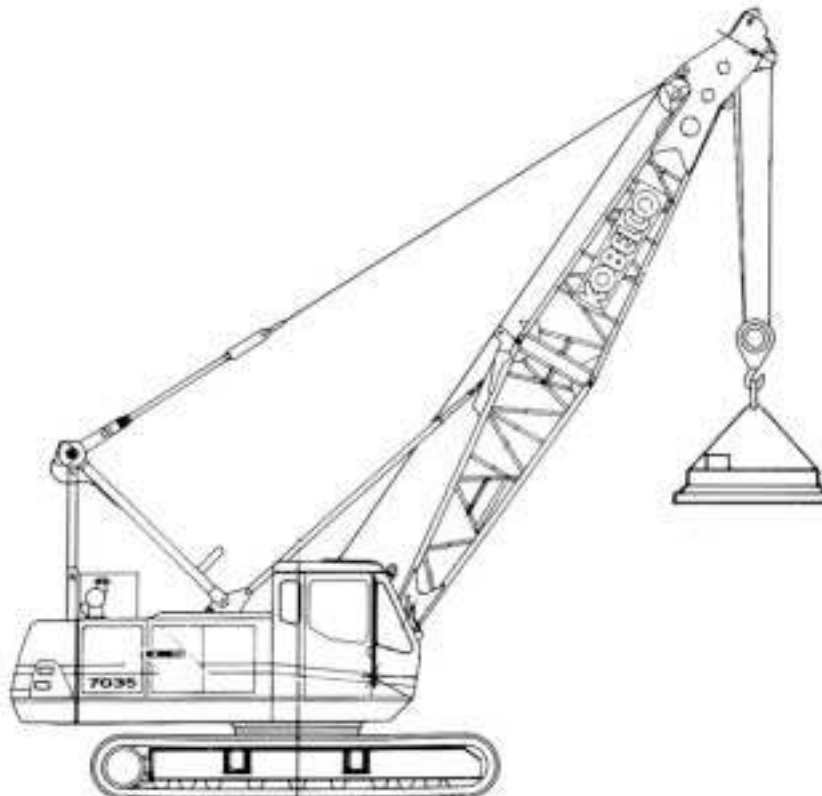

# Pile Driver

## Working Capacities with Standard Counterweight

Leader model		FL45W																																			
Diesel pile hammer	Model	K35				K25				K35				K25																							
	Hammer weight (ton)	7.5				5.2				7.5				5.2																							
Earth auger	Cap weight (ton)	1.0				0.5				1.0				0.5																							
	model	D50H				D40H				D50H				D40H																							
Earth auger	Earth auger weight (ton)	3.9				3.3				3.9				3.3																							
	Screw length (m)/weight (ton)	10.5/1.8				10.5/1.4				13.5/2.3				13.5/1.8																							
A. Boom length (m)		9.14								12.19																											
B. Leader length (m)		15								18																											
C. Pile length (m)		8.0				9.0				9.0				11.0				12.0				12.0				14.5				15.5				15.5			
R. Working radius (m)		R	W	R	W	R	W	R	W	R	W	R	W	R	W	R	W	R	W	R	W	R	W	R	W	R	W	R	W								
W. Rated load (ton)																																					
Boom angle (°)	82	—	—	—	—	—	—	—	—	—	—	—	—	—	—	5.0	8.0	5.0	8.0	4.9	6.5	—	—	—	—	—	—	—	—								
	81	—	—	—	—	—	—	—	—	—	—	—	—	—	—	9.3	8.0	5.2	8.0	5.2	5.0	—	—	—	—	—	—	—	—								
	80	—	—	—	—	—	—	—	5.0	8.0	5.0	8.0	4.9	6.5	5.5	6.5	5.5	8.0	5.5	8.0	5.5	3.5	—	—	—	—	—	—	—								
	79	—	—	—	—	—	—	6.2	8.0	5.2	8.0	5.1	6.5	5.8	5.5	5.8	8.0	5.7	2.5	—	—	—	—	—	—	—	—	—	—								
	78	—	—	—	—	—	—	5.4	8.0	5.4	8.0	5.3	6.5	6.0	4.0	6.0	8.0	—	—	—	—	—	—	—	—	—	—	—	—								
	77	4.9	8.0	4.9	8.0	5.9	6.5	5.6	7.5	5.6	8.0	5.5	5.0	6.3	3.0	6.3	8.0	—	—	—	—	—	—	—	—	—	—	—	—								
	76	5.1	8.0	5.1	8.0	5.0	6.5	5.8	8.0	5.8	8.0	5.8	4.0	6.8	2.5	6.5	7.0	—	—	—	—	—	—	—	—	—	—	—	—								
	75	5.2	8.0	5.2	8.0	5.2	6.5	6.0	5.0	6.0	5.0	6.0	3.0	6.0	1.5	6.8	6.0	—	—	—	—	—	—	—	—	—	—	—	—								
	Working weight (kg)		52.04				49.44				53.94				52.94				50.64				55.02				53.73				51.94				56.03		
Ground pressure (kg/cm <sup>2</sup> )		0.79				0.79				0.82				0.81				0.77				0.84				0.82				0.79				0.86			

Leader model		FL45W			
Diesel pile hammer	Model	K35			
	Hammer weight (ton)	7.5			
Earth auger	Cap weight (ton)	1.0			
	model	D50H			
Earth auger	Earth auger weight (ton)	3.9			
	Screw length (m)/weight (ton)	20.5/3.3			
A. Boom length (m)		18.29			
B. Leader length (m)		24			
C. Pile length (m)		17.5		18.5	
R. Working radius (m)		R	W	R	W
W. Rated load (ton)					
Boom angle (°)	82	5.4	5.5	5.4	8.0
	81	5.7	4.0	5.7	8.0
	80	6.0	2.5	6.0	8.0
	79	6.4	1.5	6.3	7.0
	78	—	—	6.6	6.0
	77	—	—	7.0	5.0
	76	—	—	—	—
75	—	—	—	—	
Working weight (kg)		54.63		53.33	
Ground pressure (kg/cm <sup>2</sup> )		0.83		0.81	

**Note:**

- 1) Crawler frames must be fully extended and locked.
- 2) Driving angle must be kept within 10° of the leader angle.

# Front Attachments

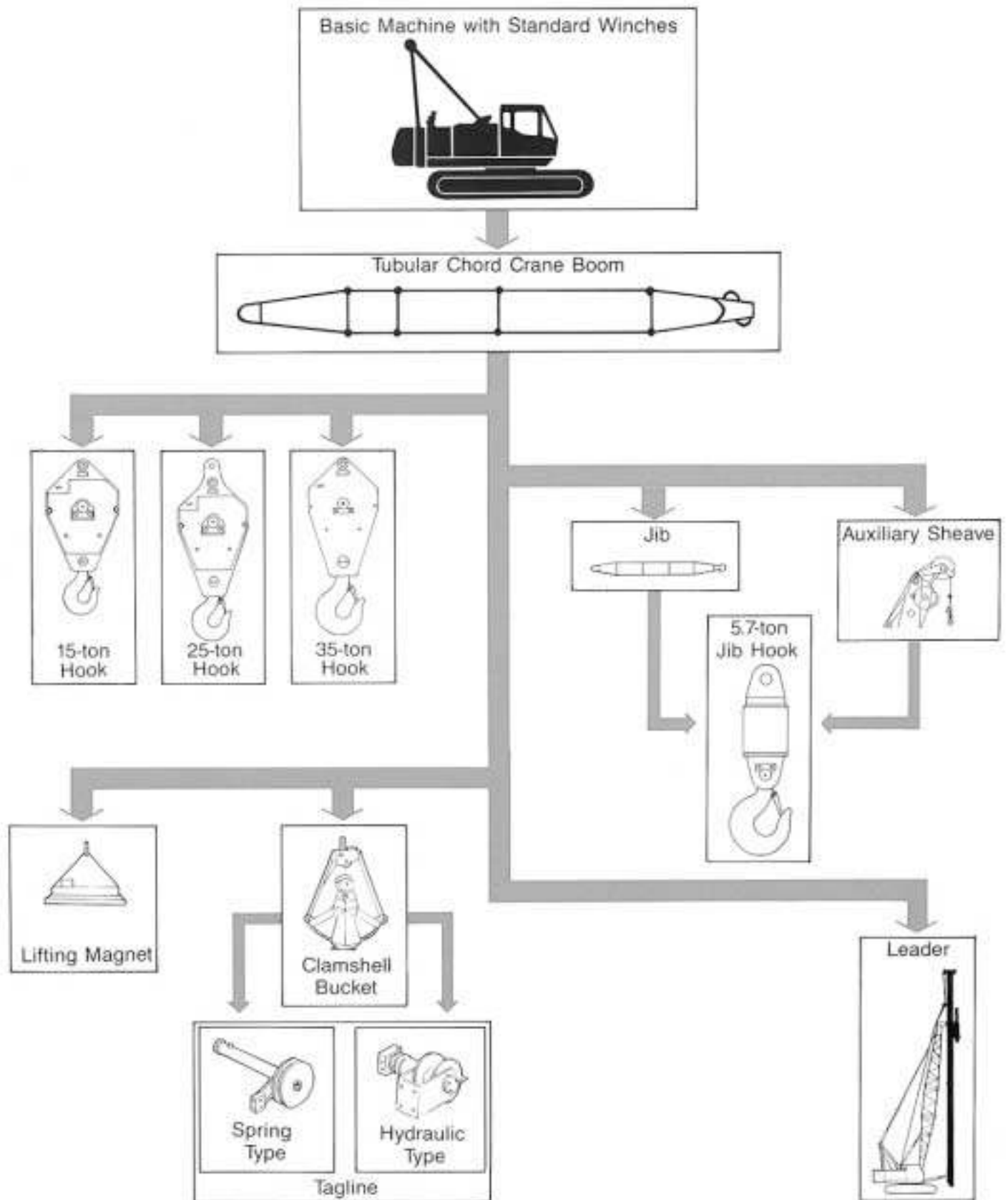

# 7035



---

**NOTE:** Due to our policy of continual product improvement, all designs and specifications are subject to change without advance notice.

**KOBELCO CONSTRUCTION MACHINERY CO., LTD.**

17-1, Higashigotanda 2-chome, Shinagawa-ku, Tokyo, 141-8626 JAPAN  
Tel: ++81 (0) 3-5789-2121 / Fax: ++81 (0) 3-5789-2134